

COMPOSITE CYLINDERS

316SS/ COMPOSITE CONSTRUCTION CYLINDERS



316SS/ Composite Cylinders



Composite Cylinders

Features

- 1. Rod & Tie Rods:** Made from high-strength, corrosion resistant 316 Stainless Steel
- 2. Versatile:** Developed for pressure ratings of 150 psi, bore sizes available from 1-1/2" thru 5"
- 3. Water, Air and Hydraulic Service**
- 4. Lightweight**
- 5. Fits Most NFPA Dimensions**

Ordering Information

MP1 - CS - 2B - 24S - .75R - .5/ MF - 6FSR1 - 6FS - C1

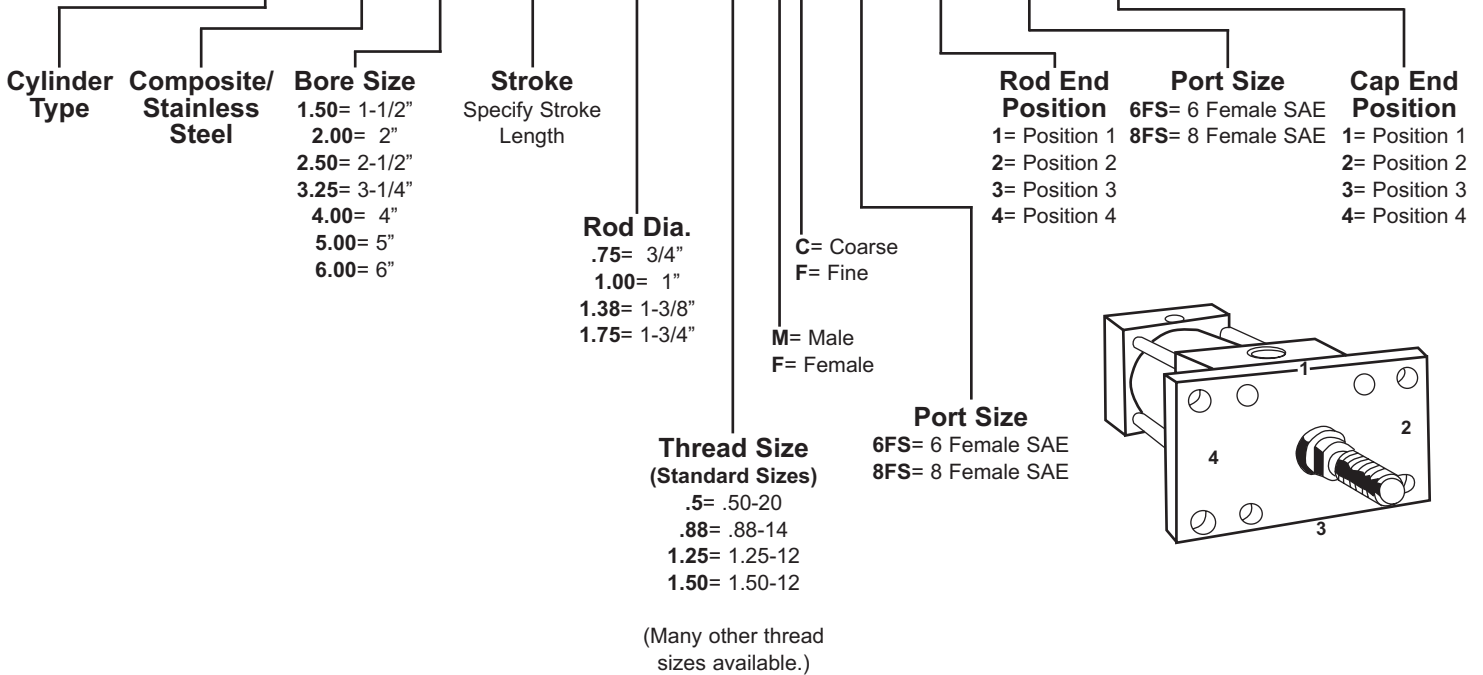

Composite cylinders materials may be applied to I5 air motor or low pressure Hydrocillator
 (Hyd. pressure 1,000 psi max)



COMPOSITE CYLINDERS

316SS/ COMPOSITE CONSTRUCTION CYLINDERS



316SS/ Composite Cylinders

Dimensional Data

MP1 Fixed Clevis Mount

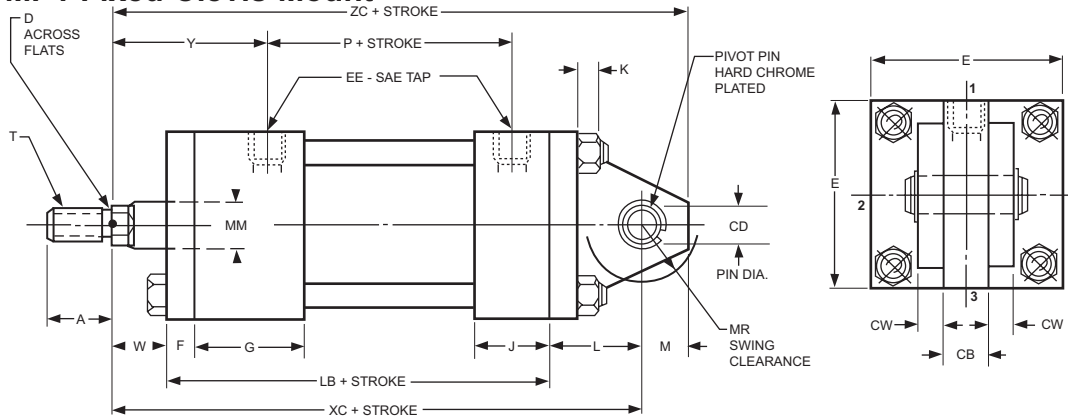

MT1 Head Trunnion Mount

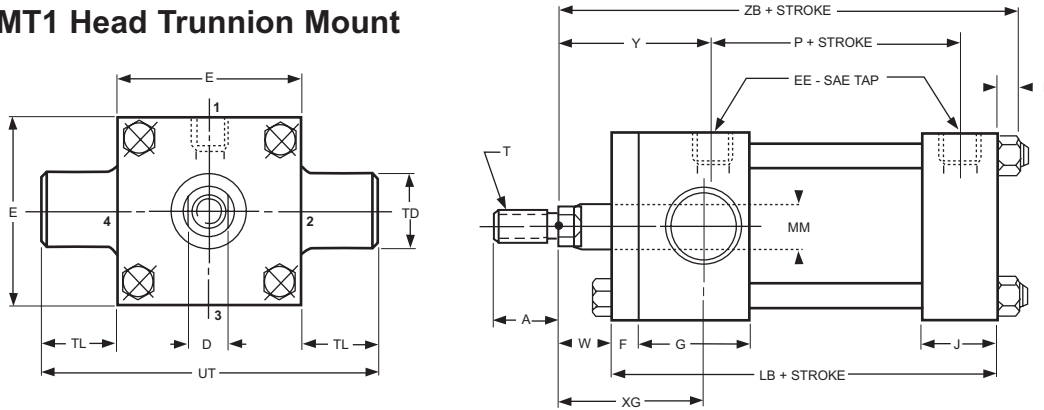

Align and mount pillow blocks to avoid bending moments in trunnions.

Standard Rod End Styles

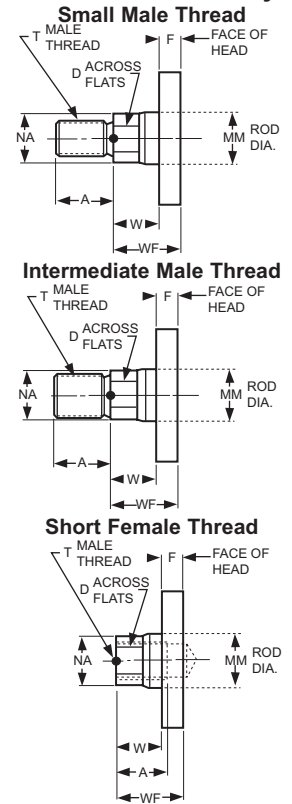

Dimension "NA" is the rod diameter minus .030 (.75 & 1.00 rods), and minus .062 (1.38 & 1.75 rods).

Units: (inches)

BORE	CB +0.16 +0.47	CD	CW	E	EE SAE	F	G	J	K	L	LB	M	MR	P	TD +0.000 -0.002	TL	UT
1.50	0.750	.500	.19	2.00	6 SAE	.38	1.50	1.00	.38	.75	4.00	.50	.62	2.31	1.000	1.00	4.00
2.00	0.750	.500	.19	2.50	6 SAE	.38	1.50	1.00	.41	.75	4.00	.50	.62	2.31	1.000	1.00	4.00
2.50	0.750	.500	.19	3.00	6 SAE	.38	1.50	1.00	.41	.75	4.12	.50	.62	2.44	1.000	1.00	5.00
3.25	1.250	.750	.38	3.75	6 SAE	.62	1.75	1.25	.53	1.25	4.88	.75	1.12	2.69	1.000	1.00	5.75
4.00	1.250	.750	.38	4.50	6 SAE	.62	1.75	1.25	.53	1.25	4.88	.75	1.12	2.69	1.000	1.00	6.50
5.00	1.250	.750	.38	5.50	6 SAE	.62	1.75	1.25	.69	1.25	5.12	.75	1.12	2.94	1.000	1.00	7.50
6.00	1.500	1.000	.38	6.50	8 SAE	.75	2.00	1.50	.69	1.50	5.75	1.00	1.38	3.19	1.375	1.38	9.25

Units: (inches)

BORE	CYLINDER		A	D	THREAD			W	XC	XG	Y	ZB	ZC
	MM ROD DIA.				SMALL MALE SM	INTER- MEDIATE MALE IM	SHORT FEMALE SF						
1.50	.75	.75	.50	.44-20	.50-20	.44-20	.62	5.38	1.75	1.88	5.00	5.88	
	.75	.75	.50	.44-20	.50-20	.44-20	.62	5.38	1.75	1.88	5.03	5.88	
2.00	1.00	1.12	.88	.75-16	.88-14	.75-16	1.00	5.75	2.12	2.25	5.41	6.25	
	.75	.75	.50	.44-20	.50-20	.44-20	.62	5.50	1.75	1.88	5.16	6.00	
2.50	1.00	1.12	.88	.75-16	.88-14	.75-16	1.00	5.88	2.12	2.25	5.53	6.38	
	1.00	1.12	.88	.75-16	.88-14	.75-16	.75	6.88	2.25	2.38	6.16	7.62	
3.25	1.38	1.62	1.12	1.00-14	1.25-12	1.00-14	1.00	7.12	2.50	2.62	6.41	7.88	
	1.00	1.12	.88	.75-16	.88-14	.75-16	.75	6.88	2.25	2.38	6.16	7.62	
4.00	1.38	1.62	1.12	1.00-14	1.25-12	1.00-14	1.00	7.12	2.50	2.62	6.41	7.88	
	1.00	1.12	.88	.75-16	.88-14	.75-16	.75	7.12	2.25	2.38	6.56	7.88	
5.00	1.38	1.62	1.12	1.00-14	1.25-12	1.00-14	1.00	7.38	2.50	2.62	6.81	8.12	
	1.38	1.62	1.12	1.00-14	1.25-12	1.00-14	.88	8.12	2.62	2.75	7.31	9.12	
6.00	1.75	2.00	1.50	1.25-12	1.50-12	1.25-12	1.12	8.38	2.88	3.00	7.56	9.38	

